

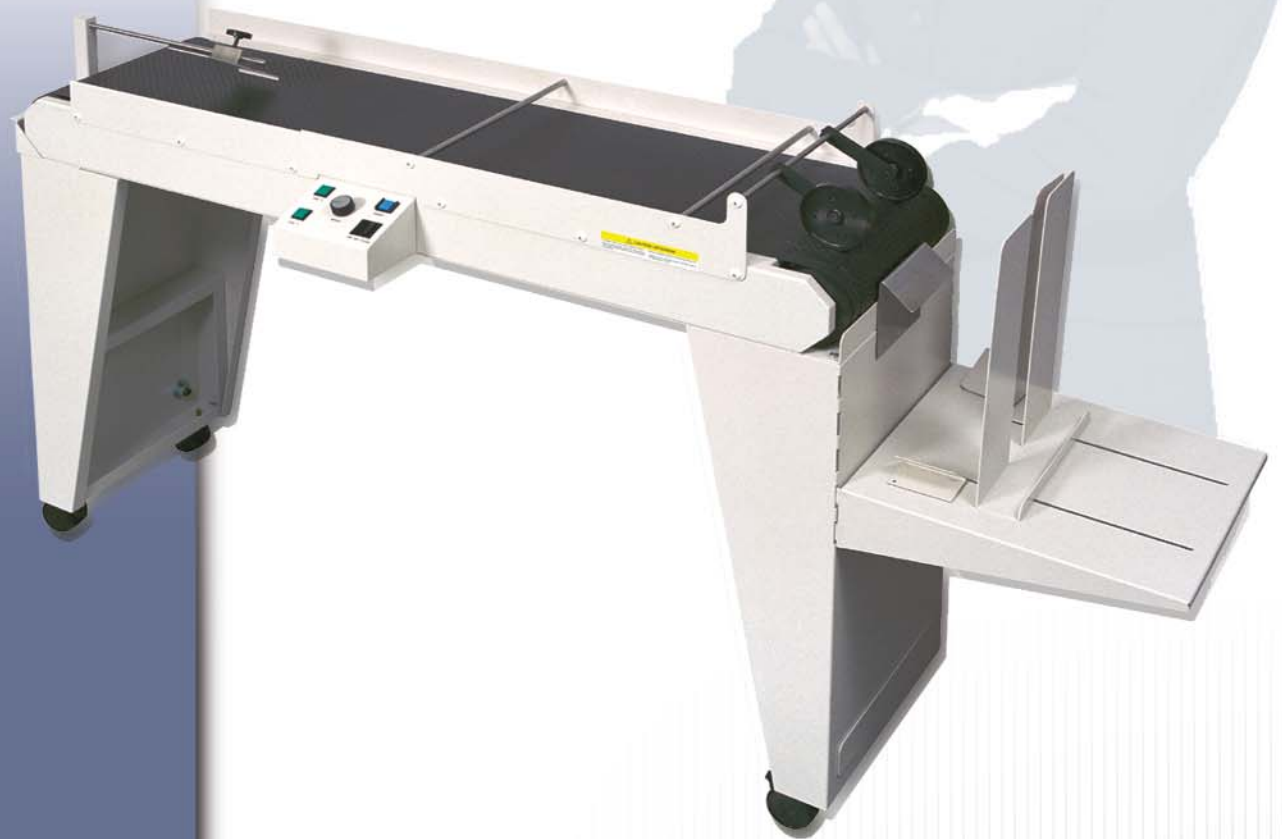

Speed Up Drying While Retaining Print Quality



Secap[®] TC48 **Vacuum Assist Conveyor with Stand**

High Quality Conveyor Controls Difficult Material

The Secap[®] TC48 conveyor features two high capacity vacuum fans that stabilize material on the conveyor. This helps control the registration and transport of difficult media. In addition, the unique design and flexible features provide:

- Adjustable drop stacking tray for convenient and hands-free stacking
- Variable speed control for handling different types of media
- Wide, perforated belt for the smooth transport of material
- Built-in interface for optional dryer

Improve Material Transport At An Economical Price

Secap's TC48 improves material processing and productivity. With the TC48's integrated vacuum assist fans, operation is practically hands-free. When material is released from the printer, it hits the knock-down guide and is held in place by the high capacity fans. The air-assisted transport improves material output, including small postcards and glossy material, which normally has a tendency to skew. Material is transported square and evenly to the exit tray accommodating media from 3" x 5" cards up to envelopes 10" x 13" in size.

Pro-mailers, lettershops, fulfillment houses, in-plant printers, and those who require a professional approach to speeding the drying process while retaining print quality can utilize all the great features and options of the TC48. The TC48's simple design provides easy operator set-up and low maintenance.

Technical Specifications

Model TC48 Conveyor

- **Speed:**
Adjustable 16 to 350 feet per minute
- **Media Size:**
Maximum: 10" x 13"
Minimum: 3" x 5"
- **Fans:**
2 high output vacuum fans
- **Controls:**
Individual on/off switch for each fan
Variable dial for controlling belt speed
On/off power switch
- **Belt:**
Wide format design providing smooth transport
Perforated for through the belt vacuum
- **Interface:**
Built-in interface for optional dryer
- **Physical Characteristics:**
Chassis: 12.25"W x 35.13"L x 3.25"H
Drop Tray: 12.25"W x 12"L x 8.25"H
Weight: 130 lbs. (with stand)
- **Power:**
120VAC., 50/60 Hz.

(Specifications subject to change without notice.)

Option: TD36 Dryer.

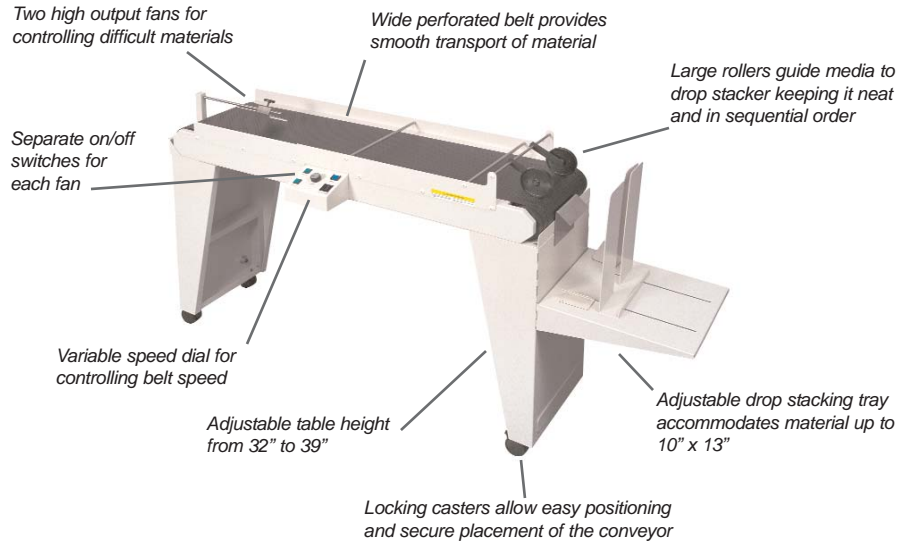

◀ Conveyor is dryer-assist ready with built-in interface allowing easy mounting for the optional TD36 Dryer



TC48 Conveyor shown with the 30K Ink Jet Address and Envelope Imager ▶



Mail Stream Management & Solutions...

10 Clipper Road
W. Conshohocken, PA 19428-2721
1.800.523.0320 • 610.825.6205 • 610.825.1397 (fax)
www.secap.com

Reorder #40415 7/05

Ask about Secap's complete line of mail stream solutions including a full line of folder inserters, inkjet address printers, both desktop and production systems, mailing and shipping software, tabbers and other mail related products and services.

Millennium Mailing Equipment
84 Harris Street
Pawtucket, RI 02861
www.millennium-mailing.com
401-729-1131